



Model 633A01

Piezoelectric USB Digital Accelerometer

Installation and Operating Manual

**For assistance with the operation of this product,
contact the PCB Piezotronics, Inc.**

Toll-free: 800-959-4464

24-hour SensorLine: 716-684-0001

Fax: 716-684-3823

E-mail: imi@pcb.com

Web: www.imi-sensors.com





Service, Repair, and Return Policies and Instructions
--

The information contained in this document supersedes all similar information that may be found elsewhere in this manual.

Service – Due to the sophisticated nature of the sensors and associated instrumentation provided by PCB Piezotronics, user servicing or repair is not recommended and, if attempted, may void the factory warranty. Routine maintenance, such as the cleaning of electrical connectors, housings, and mounting surfaces with solutions and techniques that will not harm the physical material of construction, is acceptable. Caution should be observed to ensure that liquids are not permitted to migrate into devices that are not hermetically sealed. Such devices should only be wiped with a dampened cloth and never submerged or have liquids poured upon them.

Repair – In the event that equipment becomes damaged or ceases to operate, arrangements should be made to return the equipment to PCB Piezotronics for repair. User servicing or repair is not recommended and, if attempted, may void the factory warranty.

Calibration – Routine calibration of sensors and associated instrumentation is recommended as this helps build confidence in measurement accuracy and acquired data. Equipment calibration cycles are typically established by the users own quality regimen. When in doubt about a calibration cycle, a good “rule of thumb” is to recalibrate on an annual basis. It is

also good practice to recalibrate after exposure to any severe temperature extreme, shock, load, or other environmental influence, or prior to any critical test.

PCB Piezotronics maintains an ISO-9001 certified metrology laboratory and offers calibration services, which are accredited by A2LA to ISO/IEC 17025, with full traceability to SI through N.I.S.T. In addition to the normally supplied calibration, special testing is also available, such as: sensitivity at elevated or cryogenic temperatures, phase response, extended high or low frequency response, extended range, leak testing, hydrostatic pressure testing, and others. For information on standard recalibration services or special testing, contact your local PCB Piezotronics distributor, sales representative, or factory customer service representative.

Returning Equipment – *Following these procedures will ensure that your returned materials are handled in the most expedient manner.* Before returning any equipment to PCB Piezotronics, contact your local distributor, sales representative, or factory customer service representative to obtain a Return **Warranty, Service, Repair, and Return Policies and Instructions** Materials Authorization (RMA) Number. This RMA number should be clearly marked on the outside of all package(s) and on the packing

list(s) accompanying the shipment. A detailed account of the nature of the problem(s) being experienced with the equipment should also be included inside the package(s) containing any returned materials.

A Purchase Order, included with the returned materials, will expedite the turn-around of serviced equipment. It is recommended to include authorization on the Purchase Order for PCB to proceed with any repairs, as long as they do not exceed 50% of the replacement cost of the returned item(s). PCB will provide a price quotation or replacement recommendation for any item whose repair costs would exceed 50% of replacement cost, or any item that is not economically feasible to repair. For routine calibration services, the Purchase Order should include authorization to proceed and return at current pricing, which can be obtained from a factory customer service representative.

Contact Information – International customers should direct all inquiries to their local distributor or sales office. A

complete list of distributors and offices can be found at www.pcb.com. Customers within the United States may contact their local sales representative or a factory customer service representative. A complete list of sales representatives can be found at www.pcb.com. Toll-free telephone numbers for a factory customer service representative, in the division responsible for this product, can be found on the title page at the front of this manual. Our ship to address and general contact numbers are:

PCB Piezotronics, Inc.
3425 Walden Ave.
Depew, NY14043 USA
Toll-free: (800) 828-8840
24-hour SensorLineSM: (716) 684-0001
Website: www.pcb.com
E-mail: info@pcb.com



PCB工业监视和测量设备 - 中国RoHS2公布表
 PCB Industrial Monitoring and Measuring Equipment - China RoHS 2 Disclosure Table

部件名称	有害物质					
	铅 (Pb)	汞 (Hg)	镉 (Cd)	六价铬 (Cr(VI))	多溴联苯 (PBB)	多溴二苯醚 (PBDE)
住房	○	○	○	○	○	○
PCB板	X	○	○	○	○	○
电气连接器	○	○	○	○	○	○
压电晶体	X	○	○	○	○	○
环氧	○	○	○	○	○	○
铁氟龙	○	○	○	○	○	○
电子	○	○	○	○	○	○
厚膜基板	○	○	X	○	○	○
电线	○	○	○	○	○	○
电缆	X	○	○	○	○	○
塑料	○	○	○	○	○	○
焊接	X	○	○	○	○	○
铜合金/黄铜	X	○	○	○	○	○
本表格依据 SJ/T 11364 的规定编制。						
○：表示该有害物质在该部件所有均质材料中的含量均在 GB/T 26572 规定的限量要求以下。						
X：表示该有害物质至少在该部件的某一均质材料中的含量超出 GB/T 26572 规定的限量要求。						
铅是欧洲RoHS指令2011/65/ EU附件三和附件四目前由于允许的豁免。						

CHINA RoHS COMPLIANCE

Component Name	Hazardous Substances					
	Lead (Pb)	Mercury (Hg)	Cadmium (Cd)	Chromium VI Compounds (Cr(VI))	Polybrominated Biphenyls (PBB)	Polybrominated Diphenyl Ethers (PBDE)
Housing	O	O	O	O	O	O
PCB Board	X	O	O	O	O	O
Electrical Connectors	O	O	O	O	O	O
Piezoelectric Crystals	X	O	O	O	O	O
Epoxy	O	O	O	O	O	O
Teflon	O	O	O	O	O	O
Electronics	O	O	O	O	O	O
Thick Film Substrate	O	O	X	O	O	O
Wires	O	O	O	O	O	O
Cables	X	O	O	O	O	O
Plastic	O	O	O	O	O	O
Solder	X	O	O	O	O	O
Copper Alloy/Brass	X	O	O	O	O	O

This table is prepared in accordance with the provisions of SJ/T 11364.

O: Indicates that said hazardous substance contained in all of the homogeneous materials for this part is below the limit requirement of GB/T 26572.

X: Indicates that said hazardous substance contained in at least one of the homogeneous materials for this part is above the limit requirement of GB/T 26572.

Lead is present due to allowed exemption in Annex III or Annex IV of the European RoHS Directive 2011/65/EU.

DOCUMENT NUMBER: 21354

DOCUMENT REVISION: **D**

ECN: 46162

Model 633A01 USB Digital Accelerometer



(Tablet computer not included.)

Operating Guide with Enclosed Warranty Information

3425 Walden Avenue, Depew, New York 14043-2495

Phone (716) 684-0003

Fax (716) 684-3823

Toll Free Line 1-800-959-4IMI

MANUAL NUMBER: 69747

MANUAL REVISION: **D**

ECO 49649

06/13/2019

Table of Contents

Introduction..... Page 3

Getting Started Page 4

Windows 7/8

iOS- iPad/iPhone

Android

Mac OS X

Available Software..... Page 12

Optimized Software

Compatible Software

Mounting Page 14

Standard Stud Mount Procedure

Adhesive Stud Mount Procedure

Magnetic Mount Procedure

ESD Warning Information..... Page 17

Warranty/Service

Warranty, Service & Return Procedure Page 18

Customer Service..... Page 19

Introduction

Model 633A01 is a single-axis, high-resolution, broad-frequency piezoelectric accelerometer with integrated internal digital data processing in a ruggedized housing. The sensor sends a stream of audio formatted data. The chosen software will need to have saving capabilities to store the data after capture. Typically, this will be in an audio format such as a .WAV file or an application specific format.

The sensor is a two-channel device that measures on a single axis; the same signal can be found on both channels. Channel A is suitable for measurements up to ± 20 g full scale while Channel B is the same signal scaled ± 10 g full scale. While either channel can be used, most users choose to use Channel A. A block diagram is provided below to illustrate the operation of the sensor and the development of the two output signals.

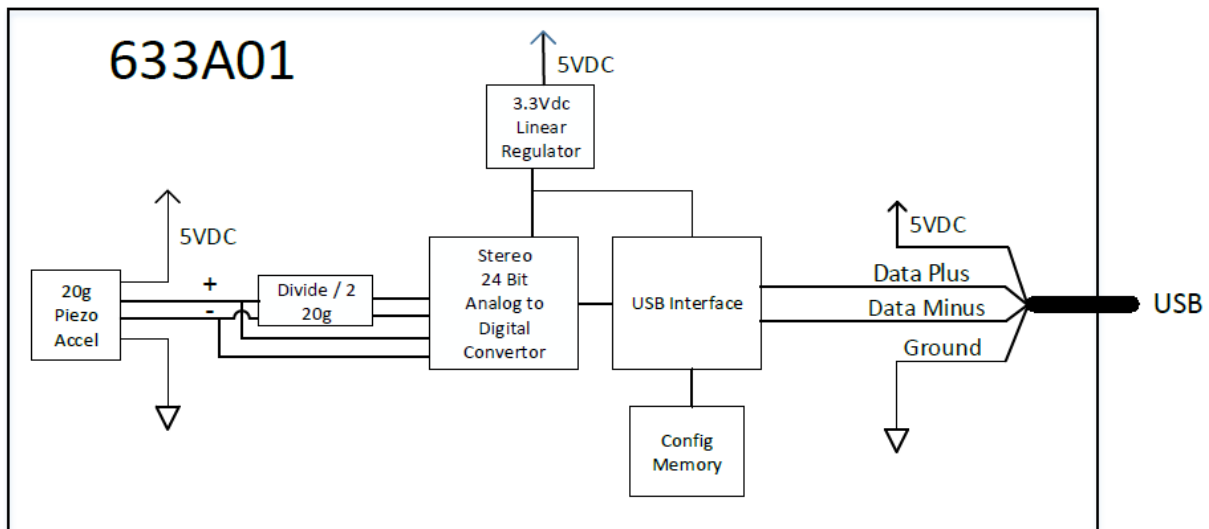

The device communicates via a USB 2.0 Full Speed communication standard. It uses a 24-bit analog-to-digital converter. Model 633A01 can support 16-bit and 24-bit resolution rates and 48, 44.1, 32, 22.05, 16, 11.025 and 8.0 kHz sample rates. Output resolution and sample rate are selectable in audio driver software. For general-purpose use, a sample rate of 48,000 Hz will work for most applications. For specific frequency measurements, the sample rate should be at least 2x the maximum expected frequency. For low frequency (< 20 Hz) applications, the 8,000 Hz rate is ideal.

Getting Started

Windows 7/8/10

1. Plug Model 633A01 into a USB port on your PC.
2. Windows should automatically detect and install the device drivers. A notification will populate in the lower right-hand corner. Sometimes the notification will not populate, so do not be concerned if you do not see the pop-up window. The drivers will still be installed automatically.

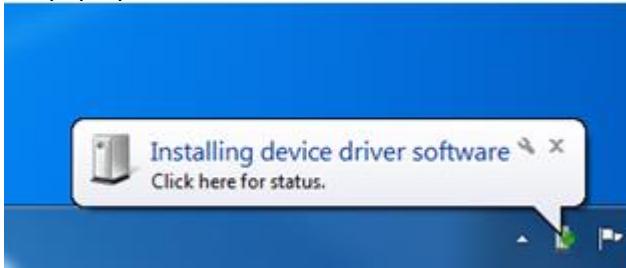

3. Right-click on the speaker icon in the notification tray.



4. Select "Recording Devices" from the menu.

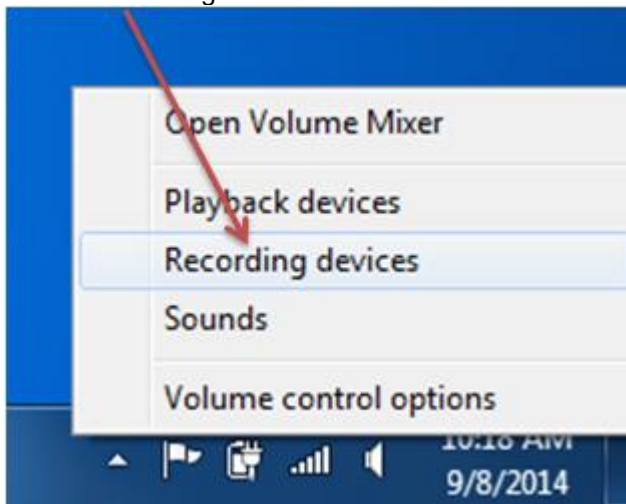

5. Clicking on “Recording Devices” will open up the Sound Menu. There will be a new “Microphone” there labeled “633A01 1XXXXXXXXXXXXXXXXXXXXXXX” where X will be numbers specific to your sensor.

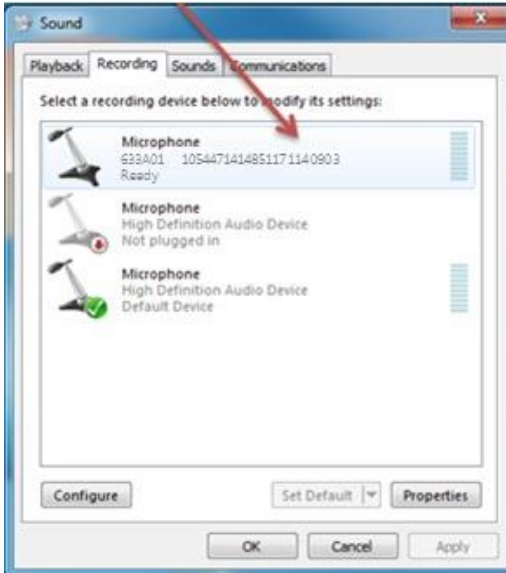

6. Click the device in the Sound Menu, which will highlight it. Then click the “Set Default” button near the bottom of the screen to set the sensor as the default recording device so that it will remain active. A green check mark should then appear next to Model 633A01 entry on the screen. (You can tap the sensor at this point and there should be activity in the amplitude meter.)

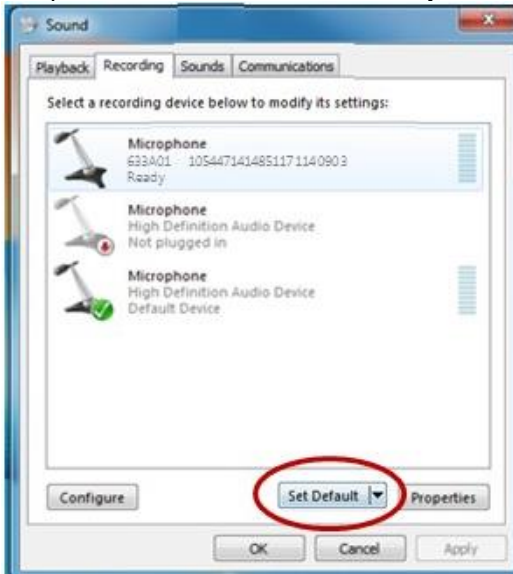

7. Next, click the “Properties” button next to the “Set Default” button.

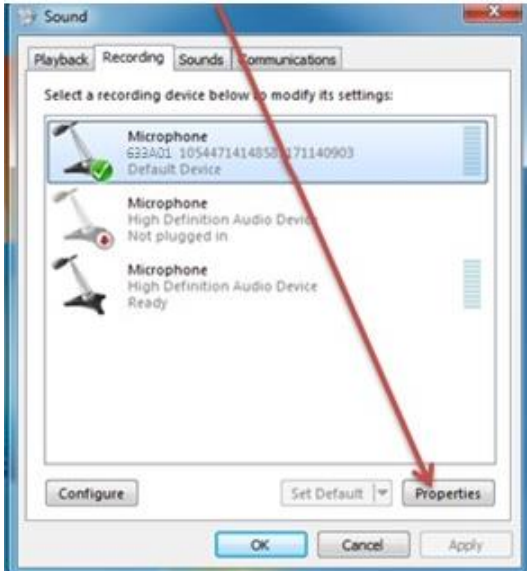

8. Select the “Advanced” tab under Microphone Properties.



9. Select a sample rate of 48,000 Hz and 24 bit (Studio Quality).

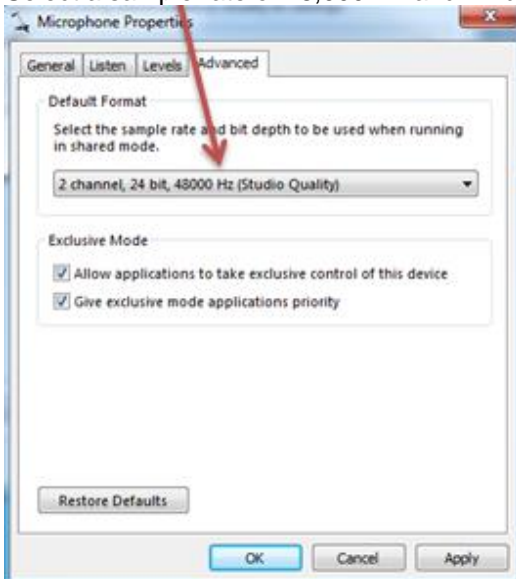

10. Save these settings by clicking the “OK” button until the windows are all closed.
11. Open any software that allows the recording of vibration or sound. See Available Software section.
12. Start recording data.

iOS for iPad/iPhone

1. Using the appropriate adaptor, plug it into your device.

Lightning to USB Camera Adaptor		30-pin to USB Adaptor
Apple Model MD821AM/A	Apple Model MK0W2	No longer produced by Apple
		

2. Connect Model 633A01 to the Type A Female USB port.
3. Open any app that allows the recording of vibration or sound. See Available Software section.
4. Start recording data.

Android

1. Using the appropriate adaptor, plug it into your device.

USB 30-pin Male to Type A Female On-The-Go (OTG) Cable	USB 2.0 Micro USB Male to Type A Female On-The-Go (OTG) Cable	USB 3.0 Micro USB Male to Type A Female On-The-Go (OTG) Cable
		

2. Connect Model 633A01 to the Type A Female USB port.
3. Open any app that allows the recording of vibration or sound. See Available Software section.
4. Start recording data.

Mac OS X

1. Plug Model 633A01 into a USB port on the Mac.
2. Click on the Apple symbol in the navigation bar on the left.

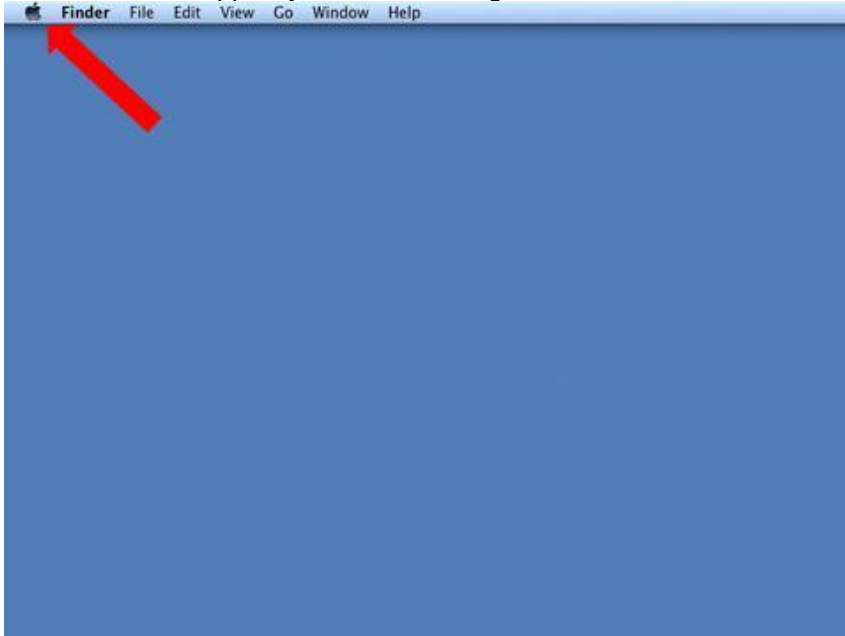

3. Select "About This Mac" from the drop-down menu.

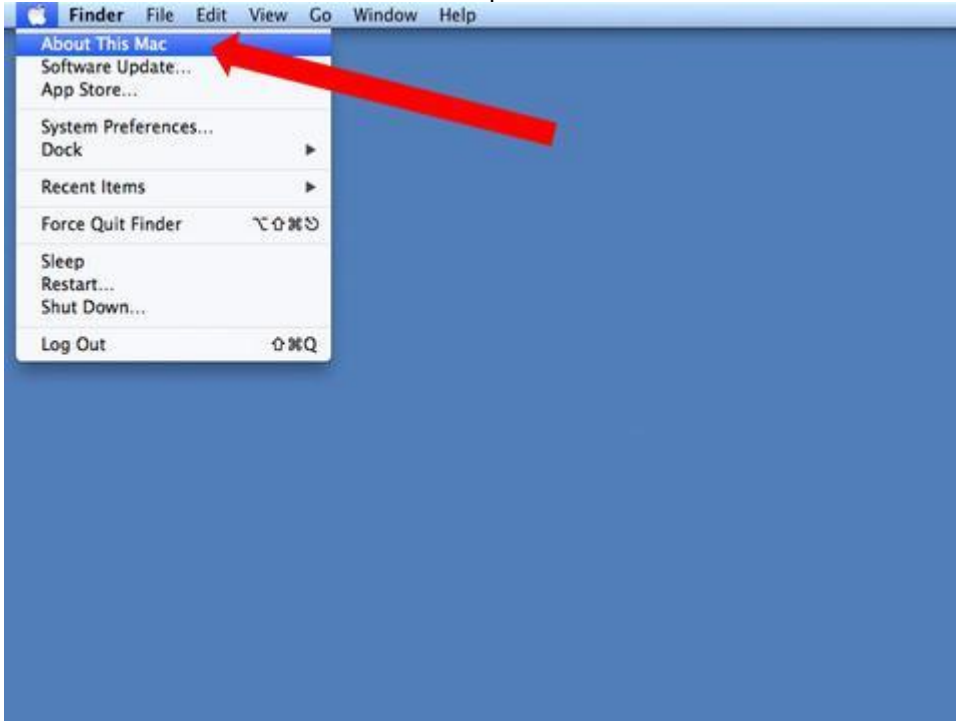

4. The "About This Mac" menu will pop up after being selected. Click the "More Info..." button, which will give you more details about your computer.



5. From this more extensive "About This Mac" menu, choose the "System Report..." button.



6. On this menu, find USB under the "Hardware" list, and select it. On the right in the main window under "USB Device Tree" you should see your sensor.

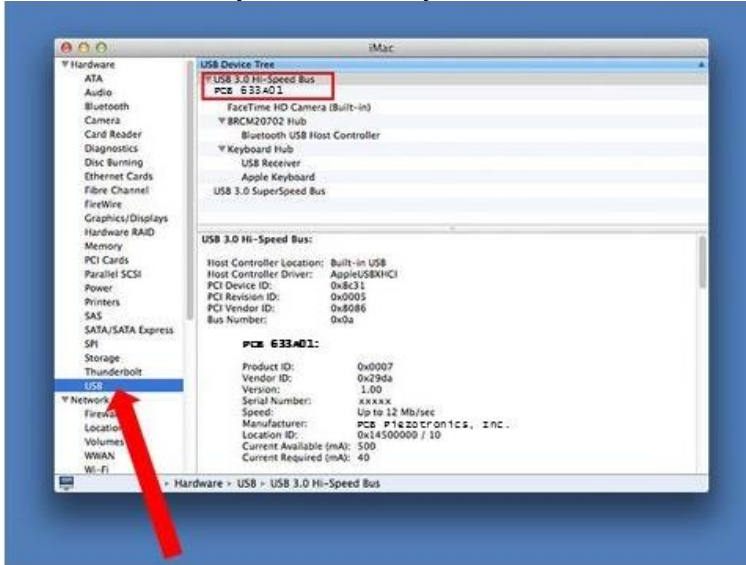

7. Open any software that allows the recording of vibration or sound. See Available Software section.
8. Start recording data.

Available Software

Below is a list of third-party software that can be used to streamline taking data.

Optimized Software: Automatically accesses the sensor's internal calibration data via the USB interface and provides calibrated values in engineering units.

Operating System			
Windows <i>(Available for web download)</i>	iOS <i>(Available in the App Store)</i>	Android <i>(Available in Play Store)</i>	macOS <i>(Available for web download)</i>
SpectraPLUS-SC by Pioneer Hill Software LLC <i>(www.spectraplus.com)</i>	VibeCheck by iTnnovate	VibeCheck by iTnnovate	SignalScope by Faber Acoustical <i>(www.faberacoustical.com)</i>
SpectraPLUS-RT by Pioneer Hill Software LLC <i>(www.spectraplus.com)</i>	SignalScope Pro 2018 by Faber Acoustical	vib.cloud by iTnnovate	SignalScope Pro by Faber Acoustical <i>(www.faberacoustical.com)</i>
Me'scope by Vibrant <i>(www.vibetech.com/mescope/)</i>	SignalScope Advanced by Faber Acoustical <i>(www.faberacoustical.com)</i>		Electroacoustics Toolbox by Faber Acoustical <i>(www.faberacoustical.com)</i>
M+P Analyzer by M+P International <i>(www.mpihome.com)</i>	SignalScope Basic by Faber Acoustical <i>(www.faberacoustical.com)</i>		
	SignalScope X by Faber Acoustical		
	Vibration by Diffraction Limited Design LLC		
	iVibraMeter by Motionics, LLC (iPad only)		
	Vibra Test Pro by Motionics LLC		

Compatible Software: Software can gather data with the sensor, may or may not have some form of manual calibration, and can be either a recorder or spectrum plotter.

Operating System				
Windows <i>(Available for web download)</i>	iOS <i>(Available in the App Store)</i>	Android <i>(Available in Play Store)</i>	macOS <i>(Available for web download)</i>	Development Environments <i>(Available for web download)</i>
Sigview by SignalLab <i>(www.sigview.com)</i>	WavePad Sound Editor by NCH Software	Spectrum Analyser by Keuwlsoft	WavePad Sound Editor by NCH Software <i>(www.nch.com.au)</i>	MATLAB® <i>(www.mathworks.com)</i>
Soundcard Oscillation by Christian Zeitnitz <i>(www.zeitnitz.eu)</i>		Spectrum Analyser by Raspberrywood		NI LabVIEW™ <i>(www.ni.com)</i>
Visual Analyser by Sillanum Soft <i>(www.sillanumsoft.org)</i>		WavePad Sound Editor by NCH Software		NI LabWindows™/ CVI <i>(www.ni.com)</i>
WavePad Sound Editor by NCH Software <i>(www.nch.com.au)</i>				
Audacity by the Audacity Team <i>(www.audacityteam.org)</i>				

Mounting

When choosing a mounting method, consider closely the advantages and disadvantages of each technique. Typical mounting types are stud, direct adhesive, adhesive mounting base and magnetic mounting base.

Note: For a complete list of product specifications, see the “Specification Sheet” and “Outline Drawing” at the end of this Manual.

Standard Stud Mount Procedure

This mounting technique requires smooth, flat contact surfaces for proper operation and is recommended for permanent and/or secure installations. Stud mounting is also recommended when testing at high frequencies.

Note: Do not attempt mounting on curved, rough or uneven surfaces, as the potential for misalignment and limited contact surface may significantly reduce the sensor’s upper operating frequency range.

	¼-28 Stud	¼-28 Captive Screw
A (in)	0.250	0.250
B (in)	0.350	0.350
Torque (ft-lb)	2 to 5	2 to 5

- Step 1: First, prepare a smooth, flat mounting surface and then drill and tap a mounting hole in the center of this area. A precision-machined mounting surface with a minimum finish of 63 µin (0.00016 mm) is recommended. (If it is not possible to properly prepare the machine surface, consider using an adhesive mounting pad as a possible alternative.) Inspect the area, checking that there are no burrs or other foreign particles interfering with the contact surface.
- Step 2: Wipe clean the mounting surface and spread on a light film of grease, oil or similar coupling fluid prior to installation. Adding a coupling fluid improves vibration transmissibility by filling small voids in the mounting surface and increasing the mounting stiffness. For semi-permanent mounting, substitute epoxy or another type of adhesive.
- Step 3: Hand-tighten the sensor/mounting stud to the machine, and then secure the sensor with a torque wrench to the mounting surface by applying the recommended mounting torque (see enclosed specification data sheet for proper mounting torque). It is important to use a torque wrench during this step. Under-torquing the sensor may not adequately couple the device; over-torquing may result in stud failure and possibly permanent damage.

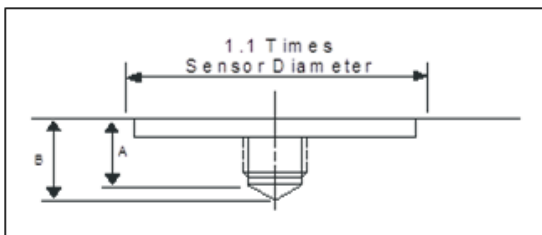

Figure 3 – Mounting Surface Preparation

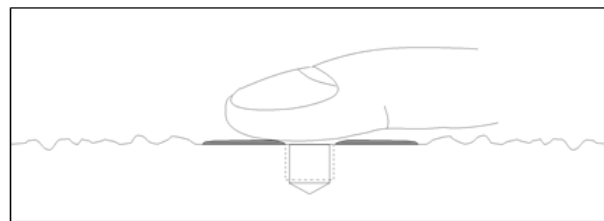

Figure 4 – Mounting Surface Lubrication

Adhesive Stud Mount Procedure

Adhesive mounting is often used for temporary installation or when the machine surface cannot be adequately prepared for stud mounting. Adhesives like hot glue or wax work well for temporary mounts; two-part epoxies and quick-bonding gels provide a more permanent mount.

Note: Adhesively mounted sensors often exhibit a reduction in high-frequency range. Generally, smooth surfaces and stiff adhesives provide the best frequency response. Contact the factory for recommended epoxies.

This method involves attaching a base to the machine surface, then securing the sensor to the base. This allows for easy removal of the accelerometer.

- Step 1: Prepare a smooth, flat mounting surface. A minimum surface finish of 63 μin (0.00016 mm) generally works best.
- Step 2: Stud-mount the sensor to the appropriate adhesive mounting base according to the guidelines set forth in Steps 2 and 3 of the Standard Stud Mount Procedure.
- Step 3: Place a small portion of adhesive on the underside of the mounting base. Firmly press down on the assembly to displace any extra adhesive remaining under the base.

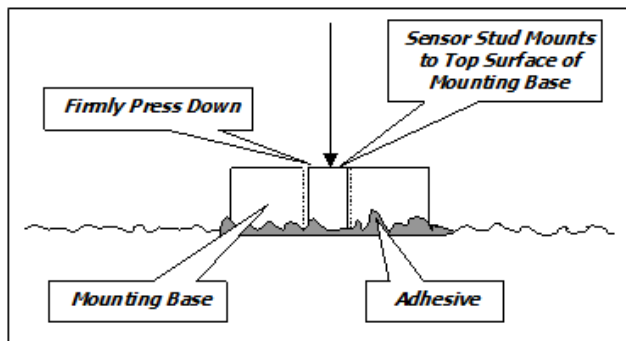

Figure 5 – Adhesive Installation of Mounting Base

Magnetic Mount Procedure

Magnetic mounting provides a convenient means for making portable measurements and is commonly used for machinery monitoring and other portable or trending applications.

Note: The correct magnet choice and an adequately prepared mounting surface are critical for obtaining reliable measurements, especially at high frequencies. Poor installations can cause as much as a 50% drop in the sensor frequency range.

Not every magnet is suitable for all applications. For example, rare earth magnets are commonly used because of their high strength. Flat magnets work well on smooth, flat surfaces, while dual-rail magnets are required for curved surfaces. In the case of non-magnetic or rough surfaces, it is recommended that the user first weld, epoxy

or otherwise adhere a steel mounting pad to the test surface. This provides a smooth and repeatable location for mounting.

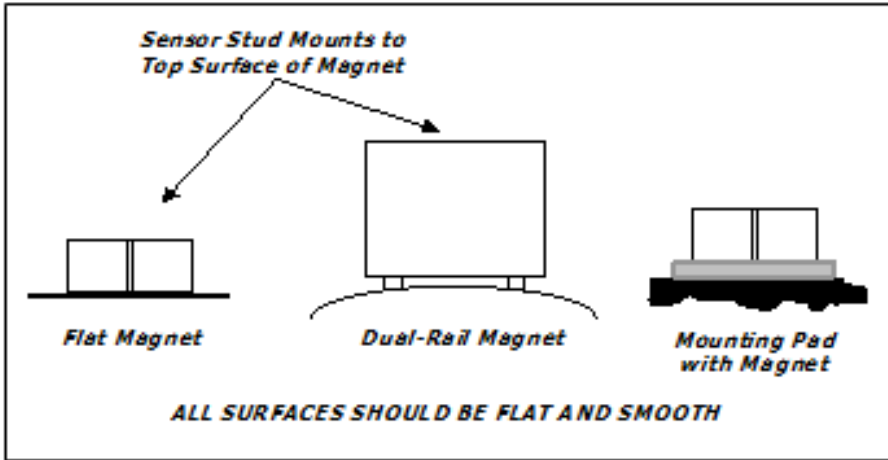

Figure 6 – Magnet Types

- Step 1: After choosing the correct magnet, inspect the unit to verify that the mounting surfaces are flat and smooth.
- Step 2: Stud-mount the accelerometer to the appropriate magnet according to the guidelines set forth in Steps 2 and 3 of the Standard Stud Mount Procedure.
- Step 3: Prepare a smooth, flat mounting surface. A minimum surface finish of 63 μin [0.00016 mm] generally works best. After cleaning the surface and checking for burrs, wipe on a light film of silicone grease, machine oil or similar-type coupling fluid.
- Step 4: Mount the magnet/sensor assembly to the prepared test surface by gently “rocking” or “sliding” it into place.

Note: *Magnetically mounting accelerometers carelessly has the potential to generate very high (and very damaging) g levels. To prevent damage, install the assembly gently. If unsure, please contact the factory for assistance.*

Warning 1 – ESD Sensitivity

The power supply/signal conditioner should not be opened by anyone other than qualified service personnel. This product is intended for use by qualified personnel who recognize shock hazards and are familiar with the safety precautions required to avoid injury.

Warning 2 – ESD Sensitivity

This equipment is designed with user safety in mind; however, the protection provided by the equipment may be impaired if the equipment is used in a manner not specified by PCB Piezotronics, Inc.

Caution 1 – ESD Sensitivity

Cables can kill your equipment. High voltage electrostatic discharge (ESD) can damage electrical devices. Similar to a capacitor, a cable can hold a charge caused by triboelectric transfer, such as that which occurs in the following:

- *Laying on and moving across a rug,*
- *Any movement through air,*
- *The action of rolling out a cable, and/or*
- *Contact with a non-grounded person.*

The PCB solution for product safety:

- *Connect the cables only with the AC power off.*
- *Temporarily “short” the end of the cable before attaching it to any signal input or output.*



Caution 2 – ESD Sensitivity

ESD considerations should be made prior to performing any internal adjustments on the equipment. Any piece of electronic equipment is vulnerable to ESD when opened for adjustments. Internal adjustments should therefore be done ONLY at an ESD-safe work area. Many products have ESD protection, but the level of protection may be exceeded by extremely high voltage.

Warranty

IMI instrumentation is warranted against defective material and workmanship for 1 year unless otherwise expressly specified. Damage to instruments caused by incorrect power or misapplication, is not covered by warranty. *If there are any questions regarding power, intended application, or general usage, please consult with your local sales contact or distributor.* Batteries and other expendable hardware items are not covered by warranty.

Service

Because of the sophisticated nature of IMI instrumentation, field repair is typically **NOT** recommended and may void any warranty. If factory service is required, return the instrumentation according to the "Return Procedure" stated below. *A repair and/or replacement quotation will be provided prior to servicing at no charge.* Before returning the unit, please consult a factory IMI applications engineer concerning the situation as certain problems can often be corrected with simple on-site procedures.

Return Procedure

To expedite returned instrumentation, contact a factory IMI applications engineer for a RETURN MATERIAL AUTHORIZATION (RMA) NUMBER. Please have information available such as model and serial number. Also, to insure efficient service, *provide a written description of the symptoms and problems with the equipment to a local sales representative or distributor, or contact IMI if none are located in your area.*

Customers outside the U.S. should consult their local IMI distributor for information on returning equipment. For exceptions, please contact the International Sales department at IMI to request shipping instructions and an RMA. For assistance, please call (716) 684-0003, or fax us at (716) 684-3823. You may also receive assistance via e-mail at imi@pcb.com or visit our web site at www.pcb.com.

Customer Service

IMI, a division of PCB Piezotronics, guarantees **Total Customer Satisfaction**. If, at any time, for any reason, you are not completely satisfied with any IMI product, IMI will repair, replace, or exchange it at no charge. You may also choose, within the warranty period, to have your purchase price refunded.

IMI offers to all customers, at no charge, 24-hour phone support. This service makes product or application support available to our customers, day or night, seven days a week. When unforeseen problems or emergency situations arise, call the **IMI Hot Line at (716) 684-0003**, and an application specialist will assist you.



3425 Walden Avenue, Depew, NY 14043-2495
Phone: (716) 684-0003 • USA Fax: (716) 684-3823 • INTL Fax: (716) 684-4703

**ICP® is a registered trademark of PCB Piezotronics, Incorporated,
which uniquely identifies PCB sensors that incorporate built-in microelectronics.**

	ENGLISH	SI	
Performance			
Sensitivity(Channel A)	334,566 counts/g	34,105 counts/(m/s ²)	[2][3]
Sensitivity(Channel B)	664,689 counts/g	67,756 counts/(m/s ²)	[2][3]
Measurement Range(Channel A)	± 20 g pk	± 196 m/s ² pk	[1]
Measurement Range(Channel B)	± 10 g pk	± 98 m/s ² pk	[1]
ADC Bandwidth(-3 dB)	9.3 to 1,374,000 cpm	0.155 to 22,900 Hz	
Frequency Range(± 5 %)	120 to 480,000 cpm	2 to 8000 Hz	[4][1]
Frequency Range(± 10 %)	90 to 660,000 cpm	1.5 to 11,000 Hz	[4][1]
Frequency Range(± 3 dB)	54 to 900,000 cpm	0.9 to 15,000 Hz	[4][1]
Resonant Frequency	≥ 1500 kcpm	≥ 25 kHz	
Mounted Resonance	1044 kcpm	17.4 kHz	[1]
Mounted Resonance Amplification	200 %	200 %	[1]
Broadband Resolution(1 to 10,000 Hz)	0.0025 g pk	0.0245 m/s ² pk	[1][3]
Non-Linearity	≤ 2 %	≤ 2 %	[5]
Transverse Sensitivity	≤ 5 %	≤ 5 %	
Environmental			
Overload Limit(Shock)	7000 g pk	68,647 m/s ² pk	
Temperature Range(Operating)	+14 to +158 °F	-10 to +70 °C	
Temperature Response(Coefficient)	0.10 %/°F	0.18 %/°C	[1]
Electrical			
Communication Standard	USB 2.0 Full Speed	USB 2.0 Full Speed	
Power Consumption	≤ 45 mA	≤ 45 mA	[1]
Internal ADC	24 bit	24 bit	
Supported Resolution Rates(Selectable)	24 bit 16 bit	24 bit 16 bit	
Supported Sample Rates(Selectable)	48 44.1 32 22.05 16 11.025 8 kHz	48 44.1 32 22.05 16 11.025 8 kHz	
Physical			
Size (Hex x Height)	1.0 in x 2.6 in	25.4 mm x 66.0 mm	
Weight	4.62 oz	131 gm	
Mounting Thread	1/4-28 UNF	1/4-28 UNF	[6]
Mounting Torque	2 to 5 ft-lb	2.7 to 6.8 Nm	
Sensing Element	Ceramic	Ceramic	
Sensing Geometry	Shear	Shear	
Housing Material	Stainless Steel	Stainless Steel	
Sealing	Welded Hermetic	Welded Hermetic	
Electrical Connector	Integral Cable	Integral Cable	
Electrical Connector	USB Type A Male	USB Type A Male	
Electrical Connection Position	Top	Top	
Cable Length	9.6 ft	2.9 m	

OPTIONAL VERSIONS

Optional versions have identical specifications and accessories as listed for the standard model except where noted below. More than one option may be used.

NOTES:

[1] Typical.
 [2] Typical value. For actual calibrated sensitivity values, refer to calibration label.
 [3] Conversion Factor 1g = 9.81 m/s².
 [4] Frequency range at highest supported sample rate.
 [5] Zero-based, least-squares, straight line method.
 [6] 1/4-28 has no equivalent in S.I. units.
 [7] See PCB Declaration of Conformance PS194 for details.

SUPPLIED ACCESSORIES:
 Model 081A40 Mounting Stud

Entered: LK	Engineer: GD	Sales: MC	Approved: BAM	Spec Number:
Date: 11/27/2018	Date: 11/27/2018	Date: 11/27/2018	Date: 11/27/2018	69746



*All specifications are at room temperature unless otherwise specified.
 In the interest of constant product improvement, we reserve the right to change specifications without notice.*

IMI SENSORS
 A PCB PIEZOTRONICS DIV.
 3425 Walden Avenue, Depew, NY 14043

Phone: 800-959-4464
Fax: 716-684-3823
E-Mail: imi@pcb.com

2

1

PCB Piezotronics Inc. claims proprietary rights in the information disclosed hereon. Neither it nor any reproduction thereof will be disclosed to others without the written consent of PCB Piezotronics Inc.

REVISIONS			
REV	DESCRIPTION		DIN
NR	RELEASED TO DRAFTING		48443

69745

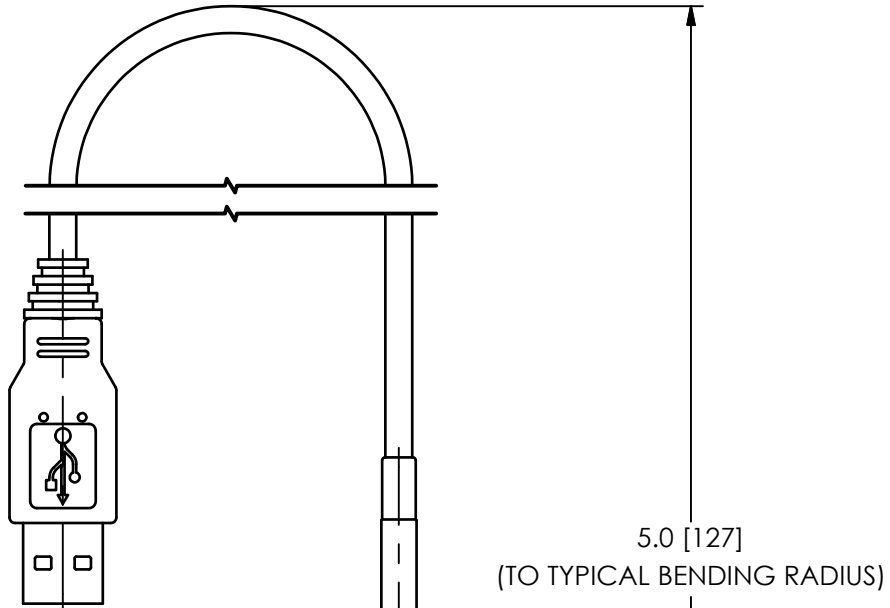

MOLDED INTEGRAL USB CABLE
9.6ft [2.9m] IN LENGTH

2X \varnothing .990 [25.15]

.05 [1.3]

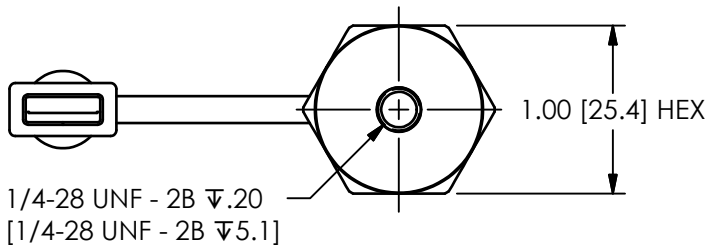

1/4-28 UNF - 2B \u2264.20
[1/4-28 UNF - 2B \u22645.1]

UNLESS OTHERWISE SPECIFIED TOLERANCES ARE:		DRAWN		CHECKED		ENGINEER		 3425 WALDEN AVE. DEPEW, NY 14043 (716) 684-0001 E-MAIL: sales@pcb.com	
DIMENSIONS IN INCHES	DIMENSIONS IN MILLIMETERS [IN BRACKETS]	KRM	7/19/18	KRM	7/19/18	GCD	7/19/18		
DECIMALS XX \pm .03 XXX \pm .010	DECIMALS X \pm 0.8 XX \pm 0.25	TITLE OUTLINE DRAWING MODEL 633A01 ACCELEROMETER							CODE IDENT. NO. 52681
ANGLES \pm 2 DEGREES	ANGLES \pm 2 DEGREES								DWG. NO. 69745
FILLETS AND RADII .003 - .005	FILLETS AND RADII 0.07 - 0.13	SCALE: 1.5X		SHEET 1 OF 1					

2

1